

Installation manual

Air heater Type QSG



EN - v3.0 / 1-2026
ORIGINAL INSTRUCTIONS

Contents

1. Introduction	3	7. Commissioning the air heater	23
1.1. Symbols used in this manual	3	7.1. Adjusting the settings	23
1.2. Warranty	3	7.2. Commissioning the air heater	23
1.3. Disclaimer	3		
2. Safety instructions	4	8. Combustion settings	25
		8.1. Adjusting the burner settings	25
		8.2. Converting to another gas type	25
3. Technical specifications	6	9. Troubleshooting	26
3.1. Performance	6	9.1. Volatile lock outs	26
3.2. Gas types	7	9.2. Temporary errors	26
3.3. Dimensions	8	9.3. Warnings	27
		9.4. Instructions	27
4. Installation	9	9.5. Further troubleshooting	28
4.1. Preparation	9		
4.2. Positioning the air heater	9	10. Maintenance	29
4.3. Gas type & connection	10	10.1. Preparation	29
4.4. Electrical connection	11	10.2. Basic maintenance	29
4.5. Room thermostat	11	10.3. Maintenance of the burner unit	29
4.6. Heat pump	12	10.4. Maintenance in dusty environments	30
4.7. Condensate drain	12		
4.8. Water connection	12	11. Electrical wiring diagram	31
5. Flue systems	17	12. Exploded view, spare parts and accessories	33
5.1. Flue terminals	17	12.1. Exploded view and spare parts	33
5.2. Flue length (max.)	18	12.2. Table with accessories QSG	34
5.3. Condensate discharge system	18		
5.4. Installation of the flue terminal	19	13. Disposal and recycling	35
6. Operating the air heater	22	14. Declaration of conformity	35
6.1. Burner cycle	22		
6.2. Minimum operating time	22		
6.3. Delta-T-regulation	22		
6.4. Summer ventilation	22		
6.5. Overheating protection	23		
6.6. Flue passage check	23		

1. Introduction

This manual is intended for the gas, electrical and mechanical installer.

This document gives instructions on how to use and maintain the air heater. It is most important to follow the instructions in this document for safe operation of this air heater.

It is important to read this document before starting the installation process. Store this document close to the air heater for quick reference.

1.1. Symbols used in this manual

DANGER! Indicates a dangerous situation that would lead to death or severe injury.

WARNING! Indicates a potentially dangerous situation that could lead to death, severe injury or serious product damage.

CAUTION! Indicates a potentially dangerous situation that could lead to injury or product damage.

NOTICE Indicates important information that is not directly related to safety.

1.2. Warranty

NOTICE Using, installing or maintaining this air heater in any other way than described in this manual may cause damage that voids the warranty.

NOTICE Failing to follow the safety instructions in this manual can lead to damage to the air heater or the installation and void the warranty.

1.3. Disclaimer

All rights reserved. No part of this installation manual may be reproduced or published by means of print, photocopy, microfilm, or in any other way, without the prior written permission of Winterwarm Heating Solutions B.V.. This also applies to any accompanying drawings, diagrams, and appendices. The information in this manual is based on the most recently available data. Winterwarm Heating Solutions B.V. reserves the right to modify or improve parts at any time without prior notice to the customer. The contents of this installation manual may be changed without prior notice. This manual has been compiled with care. Nevertheless, Winterwarm Heating Solutions B.V. accepts no liability for any errors or their consequences.

2. Safety instructions

Always follow the safety instructions in this chapter when installing, using or performing maintenance on this air heater.

2.1. Installation

CAUTION! This air heater must be installed and maintained by an authorized, qualified and competent installer, using calibrated equipment.

NOTICE This air heater must be installed and maintained in accordance with this manual, national and local building regulations and local health and safety regulations.

2.1.1. Protection against dust

CAUTION! Do not use the air heater in a very dusty environment. Dust may accumulate and cause a defect of the heater. This is also the case for the room thermostat.

2.1.2. Temperature

CAUTION! Do not install the heater in places where the temperature can rise above 35°C. Higher temperatures cause the internal components to degrade much faster.

Use restrictions	
Operating pressure	max. 5 bar
Water temperature (risk of freezing!)	min. 4°C - max. 100°C
Environmental temperature (risk of freezing!)	min. 4°C - max. 35°C

WARNING! In case of freezing, the copper tubes of the heat exchanger might get damaged, causing the heat exchanger to leak. This is not covered by the warranty.

2.1.3. Corrosive vapours

WARNING! Do not install the air heater in areas that contain any corrosive or explosive vapours. Corrosive vapours (e.g. containing Chlorine) that are sucked into the air intake will cause corrosion of the heat exchanger and a leakage of condensate and flue gas. This is also the case for the room thermostat.

2.2. Use

CAUTION! Make sure the area around the air heater is dry when performing maintenance on the air heater.

CAUTION! Always close the doors and inspection hatches of the air heater, except when adjusting and checking the appliance.

CAUTION! Do NOT cover the heater when it is in use to prevent overheating!

2.2.1. Condensate discharge

CAUTION! This air heater is a condensing heater. A condensate water discharge system must be installed according to local regulations. Never block this discharge system. In winter conditions, make sure the condensate discharge does not freeze.

CAUTION! The heat exchanger which is connected to the heat pump, has a condensate outlet too. This outlet can be used in case the QSG is set to cooling mode. The condensate from this heat exchanger may be combined with the condensate from the gas booster, but **ONLY DOWNSTREAM, AFTER** the siphon delivered with the appliance. The part upstream before the siphon is connected to the flue gasses and must not be interrupted!

2.3. Maintenance & Cleaning

Frequent maintenance and cleaning of the air heater is necessary to ensure safe and proper operation. Failure to do so could lead to damage to the heater or its surroundings and void the warranty.

2.3.1. Protection from water (IP class)

WARNING! Never use water when cleaning electrical parts.

This air heater is not waterproof and has an IP20B classification.

WARNING! Do not expose the air heater to rain, spray or dripping water.

2.4. Children and vulnerable users

WARNING! Children under the age of 3 should be kept away from the air heater unless they are under supervision.

WARNING! Children aged from 3 years and less than 8 years shall only switch on/off the appliance provided that it has been placed or installed in its intended normal operating position and they have been given supervision or instruction concerning use of the appliance in a safe way and understand the hazards involved. Children aged from 3 years and less than 8 years shall not plug in, regulate and clean the appliance or perform user maintenance.

WARNING! This air heater can be used by children aged 8 years and above and by persons with reduced physical, sensory or mental capabilities or lack of experience and knowledge, if they are supervised or instructed concerning use of the appliance in a safe way and understand the hazards involved.

CAUTION! Some parts of this product can become very hot and cause burns. Particular attention has to be given where children and vulnerable people are present.

WARNING! Children shall not play with the air heater.

WARNING! Children shall not clean and maintain this air heater without supervision.

3. Technical specifications

3.1. Performance

Technical specification	Unit	Type QSG										
		QSG6 + 10	QSG6 + 20	QSG12 + 20	QSG12 + 30	QSG12 + 40	QSG16 + 20	QSG16 + 30	QSG16 + 40	QSG16 + 50	QSG30 + 60	
Total heating power QSG, including heat pump	kW	18.0	25.2	31.2	41.0	50.8	34.9	44.7	54.5	64.0	90.0	
Electric power QSG, excluding heat pump	kW	0.27	0.27	0.47	0.47	0.47	0.85	0.85	0.85	0.85	1.6	
Maximum heating capacity heat pump*	kW	6	6	12	12	12	15.7	15.7	15.7	15.7	30	
Minimum heating capacity heat pump*	kW	2.4	2.4	4.8	4.8	4.8	6.28	6.28	6.28	6.28	12	
Nominal Load Booster (H ₁) (max)	kW	12.5	20.0	20.0	30.0	40.0	20.0	30.0	40.0	50.0	60.0	
Nominal Load Booster (H ₁) (min)	kW	4.0	6.0	9.0	9.0	12.0	9.0	9.0	12.0	15.0	18.0	
Maximum power booster	kW	12.0	19.2	19.2	29.0	38.8	19.2	29.0	38.8	48.3	58.0	
Minimum power booster	kW	4.2	6.4	9.5	9.5	12.8	9.5	9.5	12.8	15.9	19.1	
Cooling power **	kW	6.5	6.5	12	12	12	15.4	15.4	15.4	15.4	31	
Air output at full load	m ³ /h	1800	1800	4500	4500	4500	6700	6700	6700	6700	12000	
Air output at minimum load (booster off)	m ³ /h	324	324	810	810	810	1206	1206	1206	1206	2000	
Type heat pump	HPX	06A	06A	12A	12A	12A	16A	16A	16A	16A	30A	
Electrical current heat pump per phase	A	11.0 (1ph.)	11.0 (1ph.)	11.5 (3ph.)	11.5 (3ph.)	11.5 (3ph.)	12.5 (3ph.)	12.5 (3ph.)	12.5 (3ph.)	12.5 (3ph.)	22.9 (3ph.)	
Electrical power heat pump	kW	1.11	1.11	2.49	2.49	2.49	3.57	3.57	3.57	3.57	6.9	
Throw horizontal (max.)	m	15	15	20	20	20	25	25	25	25	30	
Gas connection	G"	1/2" F	1/2" F	1/2" F	3/4" M	3/4" M	1/2" F	3/4" M	3/4" M	3/4" M	3/4" M	
Voltage inner unit (50 Hz)	V	230	230	230	230	230	230	230	230	230	230	
Maximum electrical current inner unit per phase	A	1.5	1.5	1.6	1.6	1.6	3.2	3.2	3.2	3.2	7.0	
Standby power	W	7.0	7.0	7.0	7.0	7.0	9.0	9.0	9.0	9.0	13.0	
Maximum fan power	W	175	175	375	375	375	750	750	750	750	1500	
Dimensions (W × H × D)	mm	716 × 495 × 813			884 × 670 × 944			1083 × 670 × 944				1283 × 1010 × 982
Weight	kg	57	62	120	120	125	145	145	155	160	217	
Water connection	G"	3/4" M	3/4" M	1" M	1" M	1" M	1" M	1" M	1" M	1" M	1 1/2" M	
Water contents	L	2	2	3.9	3.9	3.9	6.6	6.6	6.6	6.6	13.6	
Sound level	dB(A)	35 - 54	35 - 54	35 - 63	35 - 63	35 - 63	35 - 62	35 - 62	35 - 62	35 - 62	35 - 65	
Enclosure heat loss F _{env}	%	0	0	0	0	0	0	0	0	0	0	
Emission efficiency (η _{s, f} flow)	%	92.3	96.6	99.4	97.4	97.4	97.4	95.1	97.7	96.9	98.0	
Seasonal Energy Efficiency of Space Heating η _{s, h}	%	85.2	87.2	85.8	89.6	88.9	80.7	91.4	89.4	90.4	91.4	
NOx emission (GCV)	mg/kWh	30	21	14	33	40	14	33	40	31	44	
NOx class	-	5	5	5	5	5	5	5	5	5	5	

Technical specification	Unit	Type QSG									
		QSG6 + 10	QSG6 + 20	QSG12 + 20	QSG12 + 30	QSG12 + 40	QSG16 + 20	QSG16 + 30	QSG16 + 40	QSG16 + 50	QSG30 + 60
Flue gas amount (max.)	kg/h	19.4	31.1	31.1	48.3	64.2	31.1	48.3	64.2	80.2	96.2
Flue length (max.)	m	9	9	9	9	9	9	9	9	9	9
Modulating EC fan	-	Yes	Yes	Yes	Yes	Yes	Yes	Yes	Yes	Yes	Yes

* At supply temperature (35 - 30°C), room temperature 20°C.

** Supply temperature (12 - 17°C) 27°C ambient 50% RH.

3.2. Gas types

3.2.1. Natural gas G20

Specification	Unit	Natural gas G20									
Nominal supply pressure	mbar	20									
Supply pressure (min. - max.)	mbar	17-25									
Gas category	-	I _{2H} NL: I _{2EK} DE: I _{2ELL} BE: I _{2E(s)} FR: I _{2Esi}									
Class	-	B23, C13, C33									
Specification	Unit	QSG6 + 10	QSG6 + 20	QSG12 + 20	QSG12 + 30	QSG12 + 40	QSG16 + 20	QSG16 + 30	QSG16 + 40	QSG16 + 50	QSG30 + 60
Gas consumption (max.)	m ³ /h	1.3	2.1	2.1	3.2	4.2	2.1	3.2	4.2	5.3	6.3
CO ₂ High	%	8.9	9.4	9.0	9.0	9.0	9.0	9.0	9.0	9.0	9.0
CO ₂ Low	%	8.7	8.5	8.5	8.5	8.6	8.5	8.5	8.6	8.7	8.5
O ₂ High	%	4.0	4.2	4.9	4.9	4.9	4.9	4.9	4.9	4.9	4.9
O ₂ Low	%	5.4	5.7	5.7	5.7	5.6	5.7	5.7	5.6	5.4	5.7

3.2.2. Propane

Specification	Unit	Propane G31 (P)									
Nominal supply pressure	mbar	30-50									
Supply pressure (min. - max.)	mbar	25-50									
Gas category	-	I _{3P}									
Class	-	B23, C13, C33									
Specification	Unit	QSG6 + 10	QSG6 + 20	QSG12 + 20	QSG12 + 30	QSG12 + 40	QSG16 + 20	QSG16 + 30	QSG16 + 40	QSG16 + 50	QSG30 + 60
Gas consumption (max.)	kg/h	1.0	1.6	1.6	2.4	3.2	1.6	2.4	3.2	4.0	4.8
CO ₂ High	%	10.5	10.5	10.5	10.5	10.1	10.5	10.5	10.1	10.7	10.7
CO ₂ Low	%	10.0	10.0	9.7	9.7	9.7	9.7	9.7	9.7	10.3	10.4
O ₂ High	%	4.9	4.9	4.9	4.9	5.5	4.9	4.9	5.5	4.6	4.6
O ₂ Low	%	5.7	5.7	6.1	6.1	6.1	6.1	6.1	6.1	5.2	5.1

3.3. Dimensions

The dimensions of this air heater can be found in figure 1.

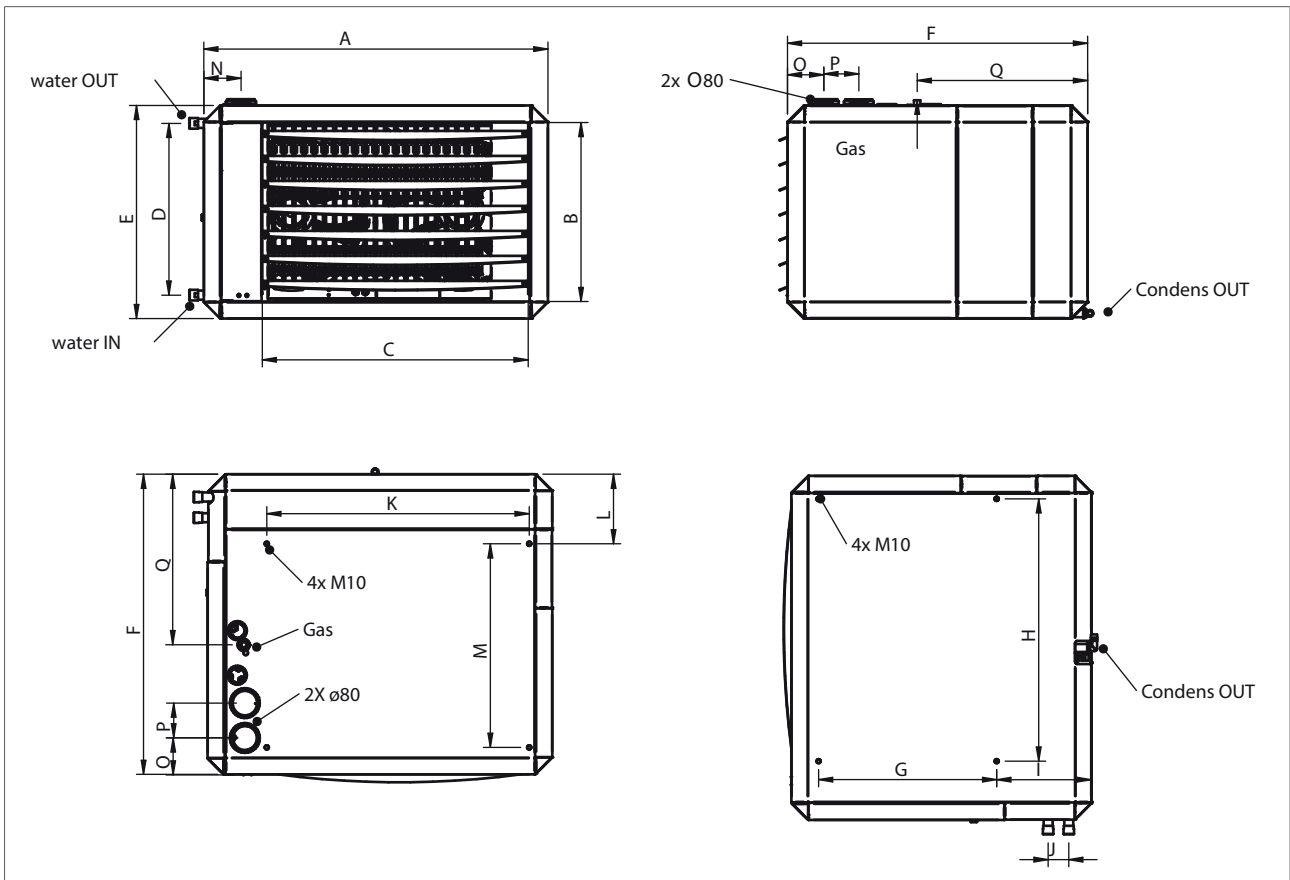

Figure 1 - Dimensions of the QSG

Dimension	Unit	QSG6	QSG12	QSG16 + 50	QSG30 + 60
A	mm	716	884	1083	1283
B	mm	422	563	563	904
C	mm	508	636	836	1005
D	mm	405	540	540	861
E	mm	495	670	670	1010
F	mm	813	944	944	982
G	mm	455	560	560	570
H	mm	465	625	824	1000
I	mm	300	300	298	330
J	mm	65	65	65	60
K	mm	465	625	825	1000
L	mm	302	219	219	200
M	mm	455	640	640	700
N	mm	94	114	114	132
O	mm	108	117	117	338
P	mm	110	110	110	110
Q	mm	401	536	536	755
Water connection	G"	3/4" M	1" M	1" M	1 1/2" M
Gas connection	G"	1/2" F	1/2" F (QSG12 + 20); 3/4" M	1/2" F (QSG16 + 20); 3/4" M	3/4" M

4. Installation

4.1. Preparation

Before installation, please use the data badge to check:

- if the heater is in accordance with the order;
- if the heater is suitable for the local present provisions (gas type, gas pressure, electrical supply etc.)

Before leaving the factory, the air heater has been tested for safety and has been set to the operating settings. It has been configured for the type of gas that is stated on the data badge. Should there be any doubt about the settings that apply to your situation, please contact your supplier.

4.1.1. Standards

NOTICE The installation must comply with all applicable local and national standards.

NOTICE The air heater must be installed in accordance with the relevant requirements of the Gas Safety regulations, Electrical installation regulations and or other local regulations that may apply.

For United Kingdom only:

NOTICE The air heater must be installed in accordance with the relevant requirements of the Gas Safety regulations, Electrical installation regulations and or other local regulations that may apply (e.g. The Institute of Gas Engineers IGE UP-1 and 2, BS6230, BS5440 building regulations and the IIE regulations that incorporate the gas safety regulations).

4.2. Positioning the air heater

Keep the following requirements in mind when choosing a location to install your air heater:

WARNING! Never install an air heater close to flammable materials.

CAUTION! Always keep a minimum distance of 2000 mm between the flue of an air heater and a heat pump (see figure 3). The fumes of the air heater can be sucked in by the heat pump and damage the heat exchanger.

- Keep sufficient distance between the heater and any obstructions. This is both for safety reasons and to allow access for service and maintenance (figure 2).

- Make sure the air flow to and from the heater is free from obstacles at least 5 metres in front of the heater. Also make sure the air intake is free from obstacles.
- Make sure enough space remains to open the door of the air heater.
- Make sure the wall can support the air heater.
- Ensure sufficient clearance distance for the flue system.

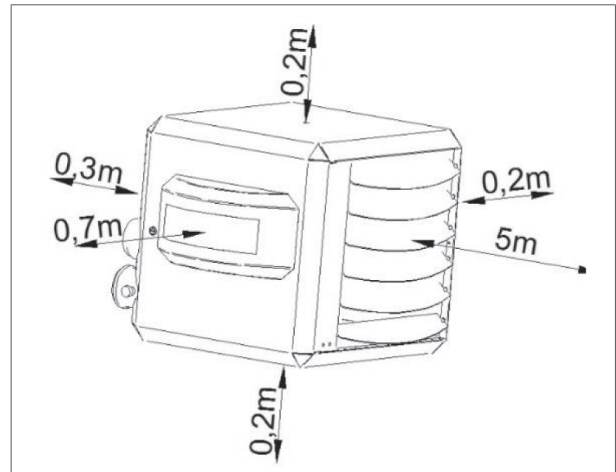

Figure 2 - Minimum clearances around the air heater

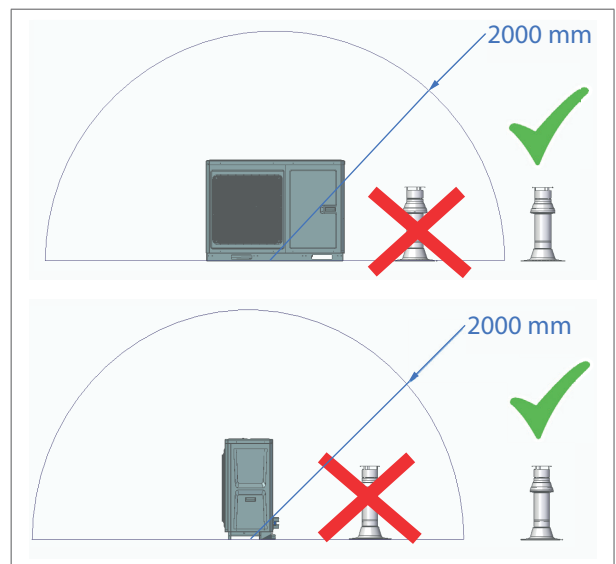

Figure 3 - Minimum distance between the flue of an air heater and a heat pump

4.2.1. Orientation

- When the heater is not installed horizontally, re-adjust the CO₂ setting from the gas valve.

4.2.2. Suspension

For the suspension of your heater, the following wall support can be used.

Model(s)	Wall support	Art. Nr.
QSG6	Wall support	GA8610
QSG12 - QSG16 + 50	Wall support	GA8580

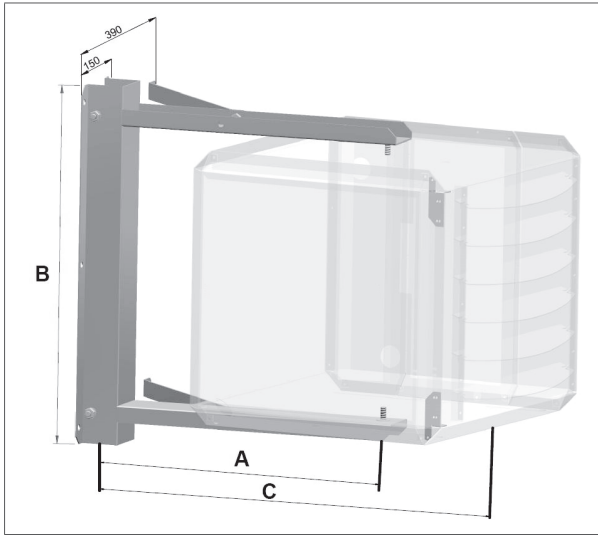

Figure 4 - Dimensions of the wall support

Model(s)	A	B	C
QSG6	550	640	1062

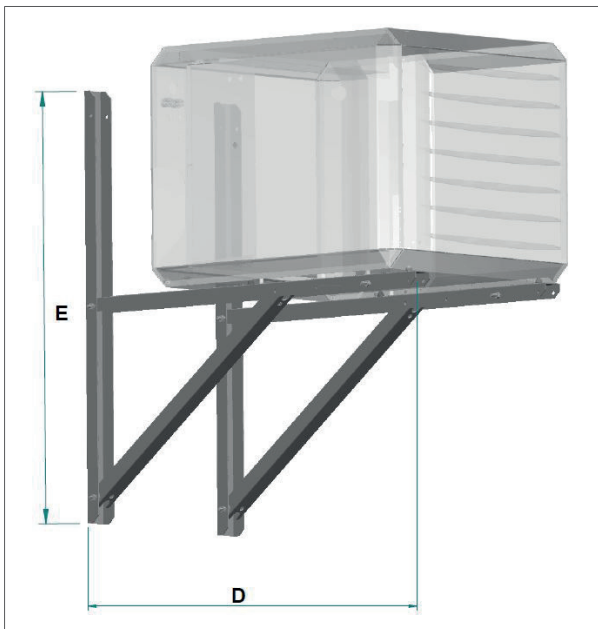

Figure 5 - Wall support (standard)

Model(s)	D	E
QSG12 - QSG16 + 50 - QSG30 + 60	1200	1200

The air heater is equipped with threaded M10 sockets to suspend the unit. For dimensions, see the table at figure 1.

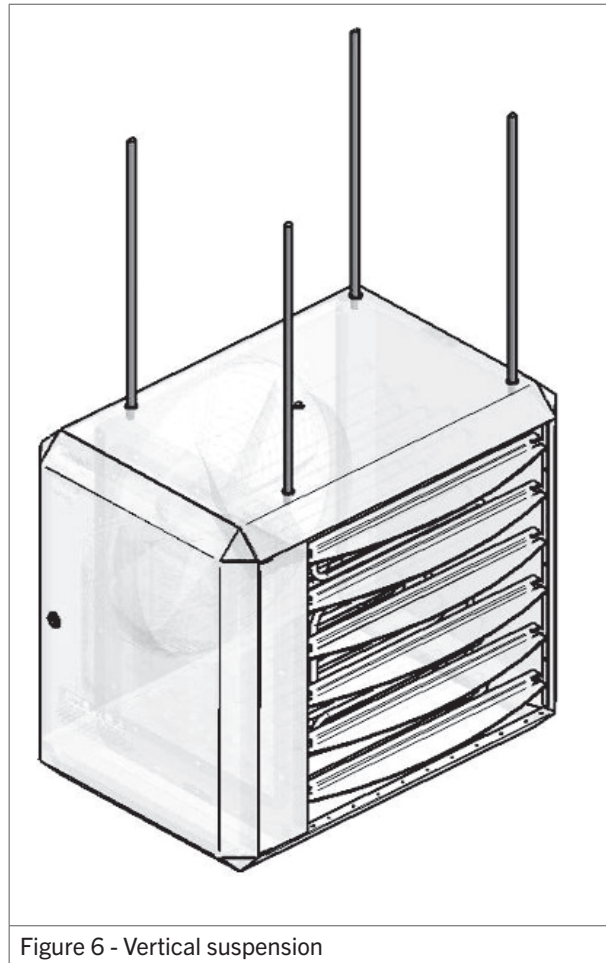

Figure 6 - Vertical suspension

NOTICE The water connections of the air heater must always remain horizontal due to venting of the internal pipes. Position the heater so that the return connection (cold water) is the lowest. Place the vent in the pipe close to the air heater.

4.3. Gas type & connection

The unit is suited for the use of natural gas or propane gas.

The specific gas type that a heater is set up for can be found on the packaging labels and on the heater badge. The heater can be converted to another gas type. Contact your supplier for more information.

The working and standing supply pressure must be a minimum of 17 mbar, and a maximum of 50 mbar, measured at the inlet pressure nipple of the gas control in the heater.

NOTICE The supply line's manual isolation valve must be placed within reach of the heater.

NOTICE All gas supply lines must be mounted without any mechanical tension.

NOTICE Always clean the inside of a gas supply line before connecting it to the air heater. Place a gas filter in the supply line when needed.

CAUTION! When using pressures above 60 mbar to test the supply lines, always close the manual isolation valve of the air heater.

For United Kingdom only:

The supply line for gas must comply with the Gas Engineers publications UP-1 and UP-2, as well as with BS 6891.

4.4. Electrical connection

The electrical installation must comply with local and national requirements as well as IEE regulations.

The heater must be electrically isolated during servicing. For the installation, use an isolation switch in the fixed wiring with a minimum contact opening gap of 3 mm, a power plug or a non-switched fuse spur, to provide full disconnection of all poles of the supply under overvoltage category III. See the electrical wiring diagram in §11

4.4.1. Power supply

The air heater requires an earthed power supply of 230 V/ AC 50 Hz. The control circuit is a four wire low voltage bus communication.

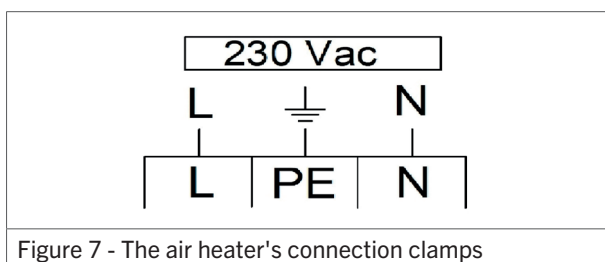

Figure 7 - The air heater's connection clamps

- Connect the wires of the mains cable to the clamps in the connection box (figure 7).
- The heater must be electrically isolated during servicing. For the installation, use an isolation switch in the fixed wiring with a minimum contact opening gap of 3 mm, a power plug or a non-switched fuse spur, to provide full disconnection of all poles of the supply under overvoltage category III. See the electrical wiring diagram in §11

4.4.2. Fuse

One fuse is present on the air heater's control board (see the electrical wiring diagram in §11).

- When replacing this fuse, always use one of the same type (5AT).

4.5. Room thermostat

The heater can only be controlled with one of the following room thermostats:

- **The Smart Controller:** a Modbus thermostat with touch control, designed specifically for hybrid heaters. For details, refer to the **Smart Controller** manual.
- **A building management system (BMS):** with modbus communication. For details, refer to the **Modbus Controller** manual.

WARNING! Never use a room thermostat to interrupt the electric power supply to the heater.

NOTICE This air heater cannot be controlled with a simple ON/OFF thermostat.

4.5.1. Installation requirements

Following these requirements when placing the thermostat to ensure the heater functions correctly:

- Make sure that air can circulate around the thermostat.
- Make sure the sun does not shine directly upon the thermostat.
- Do not place the thermostat on a cold wall.
- Place the thermostat on an inner wall free from draught.
- Never place the thermostat within the throw of the heater.
- Never mount the thermostat near the aerials of internal communication networks. These emit radiation that can disturb the thermostat. Keep several meters distance.

In all cases, the communication between the heater and the thermostat is based on a four wire, low-voltage connection. (see the electrical wiring diagram in §11). Follow these instructions to prevent malfunction of the installation and damage to the thermostat or air heater:

- Use a cable with the following specifications:
 - Signal cable.
 - Shielded.
 - Minimum dimensions: $4 \times \varnothing 0.34 \text{ mm}^2$.
 - Maximum length: 200 m.

CAUTION! Keep the thermostat cable separated from the mains cables.

CAUTION! Only connect the cable's earth shield to the earth terminal inside the air heater. Do not connect the other end of the cable's earth shield.

NOTICE A cable with a thickness of less than 0.34 mm² will result in a poor signal.

NOTICE A cable that is not shielded may result in a disturbed communication in an EMC-unfriendly environment.

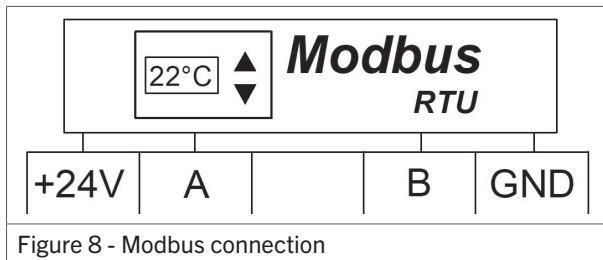

Figure 8 - Modbus connection

4.5.2. Installation of multiple appliances on one single Smart Controller or Building Management System

One single Smart Controller or Building Management System can control multiple hybrid heaters.

Consult the user manual of the Smart Controller for further information.

4.6. Heat pump

NOTICE Make sure that a heat pump is connected with the right power corresponding to the hybrid heater.

Use the same cable as specified for the thermostat in §4.5.1 for the connection between the heat pump and hybrid heater but only 2 × Ø0.34 mm².

CAUTION! Do not exchange the connection to the heat pump with the thermostat connection mentioned above. This will damage the heat pump!

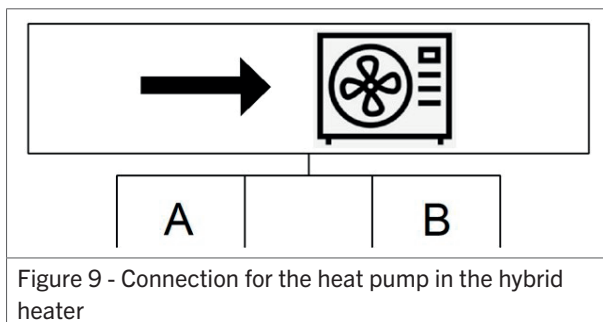

Figure 9 - Connection for the heat pump in the hybrid heater

The heat pump has a similar connection inside. The connections of the wires have to correspond for a proper communication.

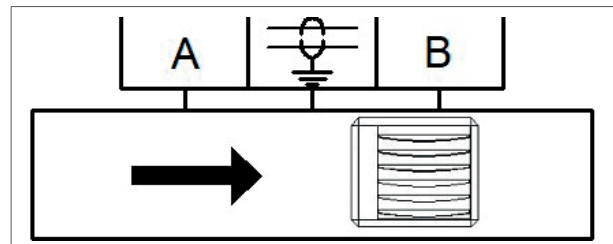

Figure 10 - Connection for the hybrid heater in the heat pump

4.7. Condensate drain

The hybrid heater has two condensate drains. The drain at the rear side is connected to a condensate collector below the heat exchanger. If the lower temperature of the heat exchanger is not set lower than 15°C, no condensate will be formed. With lower temperatures the change of condensate increase and a drainage hose may be installed in these cases.

CAUTION! The outlet at the rear side of the appliance, of the heat exchanger which is connected to the heat pump, may be combined with the condensate from the gas booster, but ONLY DOWNSTREAM, AFTER the siphon delivered with the appliance. The part upstream before the siphon is connected to the flue gasses and must not be interrupted!

4.8. Water connection

The water connections for supply and return (both 1") are marked with a blue and red label. Red indicates supply and blue indicates return. If return and supply are exchanged, the appliance will not deliver the desired capacity.

The air heater does not come with built-in venting for the water circuit. Separate vents should be installed in both the supply and return lines.

CAUTION! Avoid mechanical stress on the supply and return connections, as this can damage the heat exchanger and lead to leakage.

Use a wrench to support the connections while installing the fittings to avoid damage. Internal welds may become loose if too much force is applied!

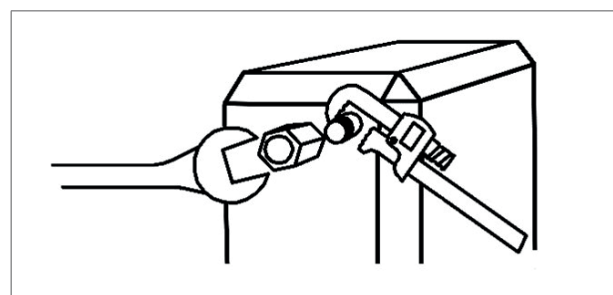

Figure 11 - Use a wrench to support the water connection during installation

Water piping installation diagram. For details, consult the manual of the heat pump.

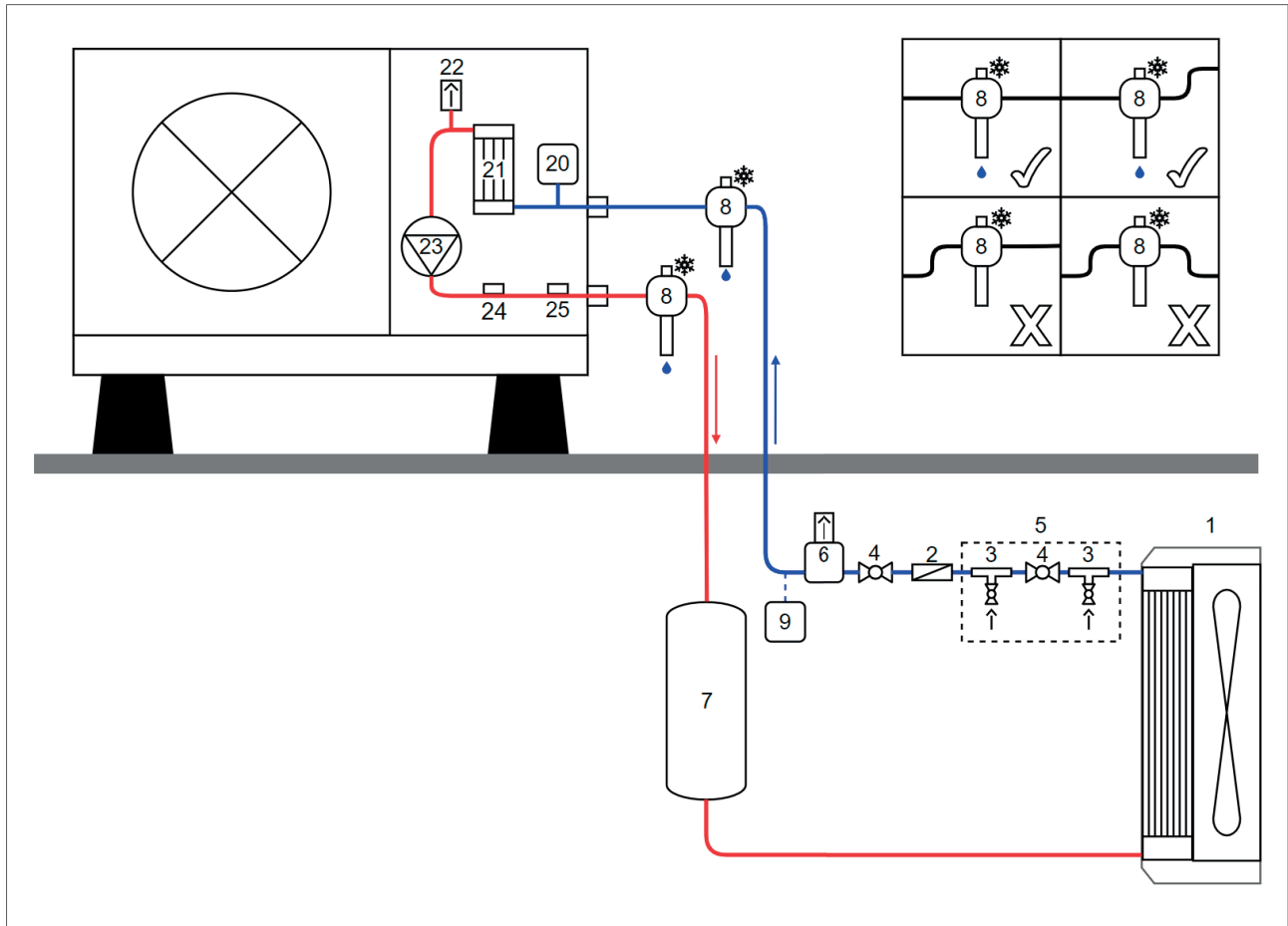

Figure 12 - Connection diagram for HPX + QSG pipes

Part number	Description
1	Indoor unit
2	Water filter
3	Filling point
4	Ball valve
5	Fill & Rinse combination
6	Air separator (flow-through air vent)
7	Buffer tank
8	Frost protection valves
9	Expansion tank
20	Expansion tank (in HPX)
21	Plate heat exchanger (in HPX)
22	Automatic air vent (in HPX)
23	Water pump (in HPX)
24	Water flow sensor (in HPX)
25	Pressure relief valve (in HPX)

4.8.1. Explanation of the components

- 2 **Filter:** Install the standard supplied water filter in the system, preferably in the supply line to the heat pump. It is advised to mount the filter between two ball valves, to be able to clean the filter without having to empty and refill the system. Mount filter in return pipe to heatpump in the lowest point possible.
- 5 **Filling accessory:** Installing this accessory eases flushing the system until all air is removed, which prevents trapping air into the system during the filling process. The filling accessory can be composed of a ball valve and two T-pieces with small shut-off valves.



Figure 13 - Filling accessory



Figure 14 - A ball valve and two T-pieces with small shut-off valves

- 7 **Buffer tank:** Buffer tank is necessary in case of short piping, where the water volume of the system is less than the value in the table in 4.8.2.
- 8 **Anti-Frost valve:** Place outside, with the opening AND outlet of the heat pump. Place these valves lower than the opening and outlet of the heat pump. The valve will open when the water temperature is below the set value. This low temperature will only be caused by a large electrical breakdown. If glycol or any other means is used to prevent freezing, frost valves do not need to be installed.
- 20 **Expansion tank:** The heat pump has a small internal expansion tank. If the water content of the system is too high, then an extra expansion tank will be needed.
Expansion vessel is necessary when exceeding a certain length only. See the manual of the heat pump for details.
- 21 **Pressure meter:** To check if there is sufficient water pressure in the system, install a pressure gauge. (The pressure cannot be digitally read from the thermostat).

22 **Automatic venting:**

PAY ATTENTION! Air in the pipes is a common cause of disruption. Use an automatic vent that removes small air bubbles from the water. Simple cheap vents will usually not do the job. One quality vent should be enough, but optionally a vent in both the supply and return line are recommended.



Figure 15 - Air vent

- 25 **Expansion Valve:** The heat pump is provided with a pressure safety valve that opens when the water pressure becomes too high. For extra safety measures, install an extra expansion valve.

4.8.2. Expansion tank and water content

The heat pump has an internal expansion tank. The storage of this expansion tank is not very large, but generally sufficient to create a good installation. An extra expansion tank will not be needed. Read below when it is required to install an extra expansion tank.

Table for deciding whether an extra expansion tank is required:

Type	Built-in expansion tank	Maximum system storage without extra expansion tank
HPX06A	2 litres	35 litres
HPX12A - HPX16A	3 litres	55 litres
HPX30A	10 litres	205 litres

Maximum system storage: Do not take the contents of the heat pump and the distribution system in this calculation. This only refers to the piping and any additional fittings. If the system capacity is exceeded, an extra expansion tank must be installed.

Minimum system capacity: for the pump to function properly and to ensure a reliable defrost cycle for the outdoor unit in winter, the MINIMUM system capacity specified below must be maintained. These values do NOT

include the capacity of the built-in expansion vessel. They refer to the capacity of all pipes, the delivery system and any buffer tank.

Model	Minimum system capacity (L)
HPX06	20
HPX12	30
HPX16	40
HPX30	70

4.8.3. Pipe diameter

Do not install pipes with an internal diameter that is too small.

Internal diameters that are too small cause excessive resistance to the high water flow of the heat pump.

Do not use an INTERNAL DIAMETER smaller than 25 mm (1 inch) with the HPX06A-HPX16A, and do not use an INTERNAL DIAMETER smaller than 38 mm (1.5 inches) with the HPX30A.

If the pipe is too long or has too many bends, the resistance of the pipes will become too great. In this case, use a larger diameter to prevent malfunctions with the heat pump.

If you are unsure about the water-side resistance, have it checked by an expert. It is better to use a larger internal diameter for the pipes. It is expensive to replace a pipe once it has been installed if faults occur.

Practical tips:

- Use corrugated pipes as little as possible. These pipes are very flexible and easy to install, but they also have very high internal resistance.
- Try to minimise the number of turns and avoid short sharp turns (knee).

4.8.4. Filling pressure

The expansion tank in the unit has a pre-pressure of 1.5 bar. The system filling pressure should preferably be between 1.5 and 2 bar. The device has a hydraulic working range of 0.5-2.5 bar. If the pressure exceeds 2.5 bar, the safety mechanism will be triggered, and water will be discharged.

4.8.5. If the air heater is installed at a higher location than the heat pump

If the air heater is installed 12 metres higher than the heat pump, the pressure in the built-in expansion tank will be too low. The pressure will need to be increased in such

cases. Please contact your distributor if this applies to your installation. It is possible that the installation may not be feasible.

4.8.6. Maximum allowable resistance and minimum flow

The heat pump moves a large amount of water. It moves much more water than a traditional central heating boiler.

Therefore, use pipes with a sufficiently large diameter and as few bends as possible.

The heat pump is equipped with an internal modulating water pump. The minimum flow required by this pump to function properly is:

Type	Minimum flow (m ³ /h)	Maximum resistance pipe system (m _{wk})
HPX06A	1.1	7.7
HPX12A	1.5	7.1
HPX16A	2.0	5.6
HPX30A	3.4	13.8

CAUTION! If the maximum flow is not achieved, the heat pump will not be at its full capacity and might malfunction.

4.8.7. Available external static pressure on the exhaust pipe

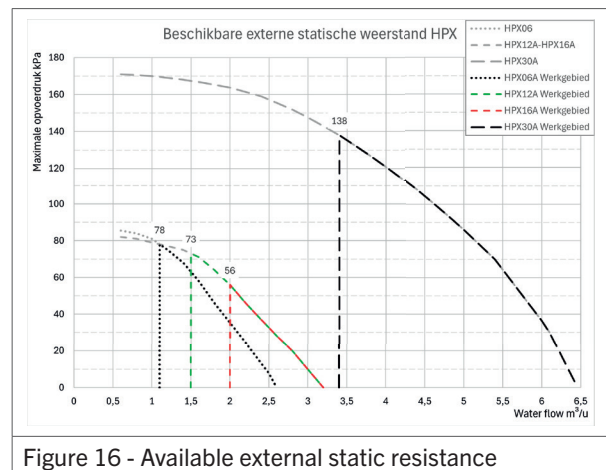

Figure 16 - Available external static resistance

Note: See the curve above for the maximum external static pressure. The water pump has a variable frequency. While operating the water pump will change the power based on the actual loading.

4.8.8. Requirements for water quality

To prevent issues in the water circuit, the water has to meet the quality criteria below.

Parameter	Parameter value	Unit
pH (25°C)	6.8 - 8.0	-
Turbidity	< 1	NTU
Chloride	< 50	mg/L
Fluoride	< 1	mg/L
Iron	< 3	mg/L
Sulfate	< 50	mg/L
SiO ₂	< 30%	mg/L
Hardness (CaCO ₃)	< 70	mg/L
Nitrate (telling N)	< 10	mg/L
Conductivity (25°C)	< 300	ηs/cm
Ammonia (number N)	< 0.5	mg/L
Alkalinity (amount CaCO ₃)	< 50	mg/L
Sulfide	Under the range of detectability	mg/L
Oxygen	< 3	mg/L
Sodium	< 150	mg/L

Note: When the circulation water does not meet the criteria in the table, add a water softener.

4.8.9. Filling procedure

NOTE Before commissioning, the dust cap on the automatic air vent must be loosened by two turns. However, in the event of leakage, it must be tightened.

PAY ATTENTION! This is an automatic air vent, not a pressure relief valve!



Figure 17 - Cap automatic air vent

Open all air vents and start filling the system with water or water mixed with antifreeze.

Use a filling accessory as in figure 13 and 14. Open both the supply and return valve and close the middle valve. Keep supplying water until no more air comes out of the return valve to make sure the system is air-free. Then close both the supply and return valve and open the intermediate valve.

5. Flue systems

To ensure safe and proper use, this air heater must be connected to a flue system. This flue system must be installed according to this manual as well as national and local regulations. A flue system consists of a flue terminal, piping and an optional condensate discharge system.

In the event that combustion air is directly drawn from the installation space (installation according to appliance class B23), sufficient fresh air supply must be ensured, in accordance with the applicable regulations.

CAUTION! Do not use flue terminals for condensing appliances on non-condensing heaters. This can lead to water inside the flue system.

NOTICE Only use the prescribed flue material for the roof terminal, wall terminal and for the piping between the heater and the terminal. This is the only way the installation will be approved.

NOTICE Local regulations can require the flue terminal to be placed at least 0.6 m above roof level.

NOTICE Local regulations can require a minimum distance between the flue terminal and air ventilation openings on the building.

5.1. Flue terminals

The following flue terminals are compatible with this air heater:

Model(s)	Vertical discharge	
	Flue terminal	Art. Nr.
QSG6, 12, 16, and 30	DDV 80/125 HR	IA8214*

* For $h > 0,5\text{m}$ above the roof, use art.nr. IA8217

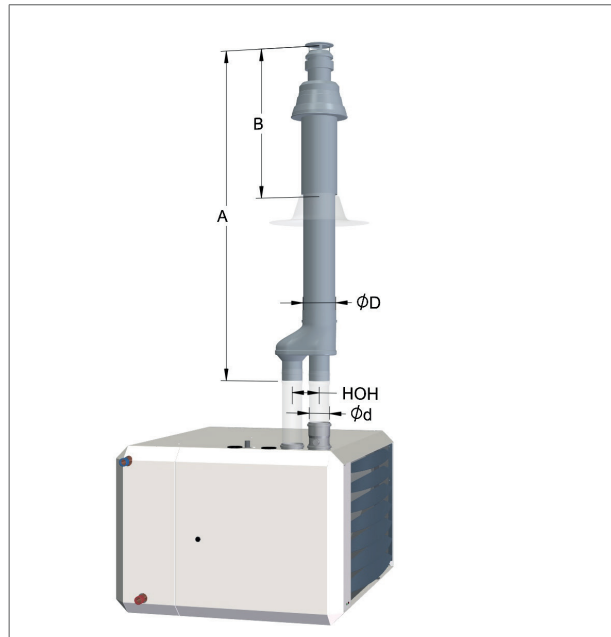

Figure 18 - Vertical flue terminal QSG6, 12, 16, and 30

Model(s)	Horizontal discharge	
	Flue terminal	Art. Nr.
QSG6, 12, 16, and 30	CT 80/125	IA8216

Dimension	QSG6, 12, 16, and 30
A (mm)	1370
B (mm)	575
d (Ø mm)	80
D (Ø mm)	125
HOH (mm)	110
E (mm)	610
F (mm)	635

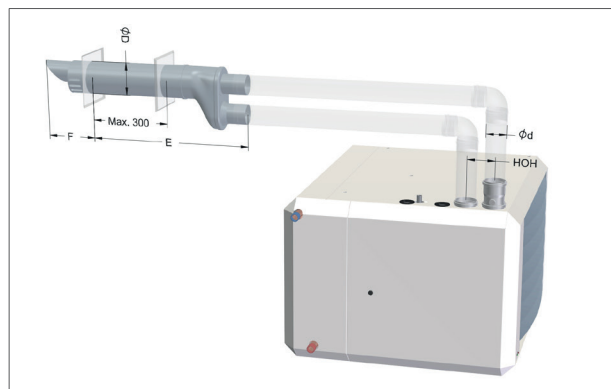

Figure 19 - Horizontal flue terminal QSG6, 12, 16, and 30

5.1.1. Flue material

Only use CE marked flue material from the manufacturers Muelink & Grol (M&G) and Burgerhout.

Use type Alu-fix with a minimum temperature class of T120 P1. (Alu-Fix has a standard temperature class of T200 nowadays).

Use flue pipes with the same diameter as the flue spigots on the heater.

Contact your supplier to purchase these flue materials.

NOTICE Different manufacturers use different connections systems for flue pipes. Do not combine systems from different manufacturers.

5.2. Flue length (max.)

The maximum straight length between the air heater and its flue terminal for both orientations is:

- Horizontal & vertical: 9 meters.

Bends that are used in the connection between an air heater and the flue terminal cause a decrease in pressure:

- Using a 90° bend decreases the maximum length of the connection by 2 meters.
- Using a 45° bend decreases the maximum length of the connection by 1 meter.

For further information regarding the flue system, please contact your supplier.

5.3. Condensate discharge system

Condensate is discharged from the air heater/flue terminal through a discharge pipe. The discharge hose (Ø25 mm) is located on the bottom of the heater (figure 20).

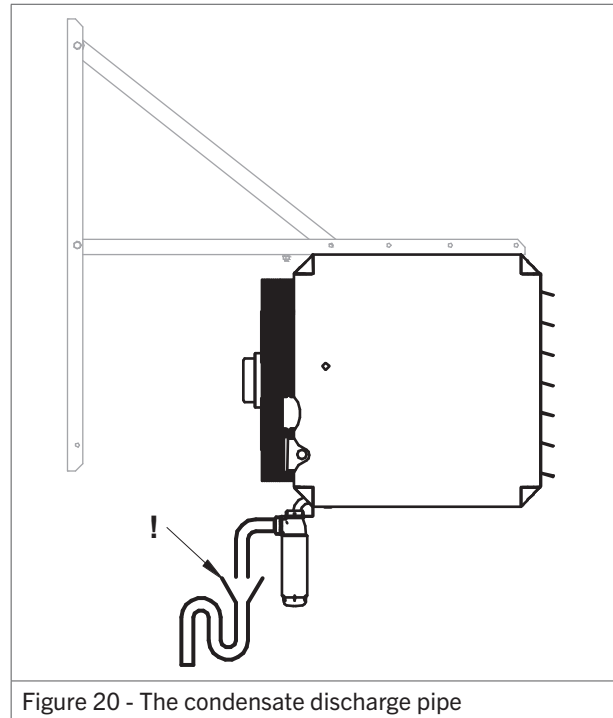

Figure 20 - The condensate discharge pipe

To install the condensate discharge system, do the following:

- Connect the discharge pipe to the siphon that is delivered with the air heater.
- Connect the other end of the siphon to a discharge system with the following requirements:
 - Min. Ø25 mm pipes.
 - Min. downward inclination of 50 mm/m.
 - Max. horizontal length of 5 m.
- Install a second siphon with an open inlet. This ensures that the condensate can always exit the heater.
- Fill both siphons with water. This prevents flue gases from flowing into the room or pipework.
- Connect the discharge system to the sewer.

WARNING! Do not let the condensate drip on the roof or roof edge of the building. This can cause dangerous ice to form in the winter. Condensate must always be discharged to the sewer.

CAUTION! The outlet at the rear side of the appliance, of the heatexchanger which is connected to the heatpump, may be combined with the condensate from the gas booster, but **ONLY DOWNSTREAM, AFTER** the siphon delivered with the appliance. The part upstream before the siphon is connected to the flue gasses and must not be interrupted!

CAUTION! Never close the air heater's condensate discharge pipe. This will cause the heater to stop working.

CAUTION! In the winter, ice can form and block the condensate discharge pipe. Protect the condensate drain from freezing to prevent this.

NOTICE The condensate discharge system must be connected according to local and national regulations.

The following table describes the maximum amount of condensate that can form per hour for each model:

Model	Max. condensate rate (L/h)
QSG6 + 10, QSG6 + 20, QSG 12 + 20, QSG 16 + 20	2
QSG12+ 30, QSG12 + 40, QSG16 + 30, QSG16 + 40	3
QSG12 + 30, QSG12 + 35, QSG12 + 40, QSG16 + 30, QSG16 + 35, QSG16 + 40	3
QSG16 + 50, QSG30 + 60	4

5.4. Installation of the flue terminal

There are flue terminals available for installation through a roof or through a wall.

NOTICE The flue terminal must be installed according to local and national regulations.

NOTICE Do not combine components or materials from different manufacturers.

5.4.1. Installation - Roof terminal

To install the flue terminal in the roof, do the following:

5.4.1.1. Preparation

1. Check all components for possible damage.
2. Determine the roofing type:

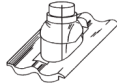
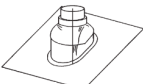
			
	Flat roof flashing	Synthetic tile	Universal pitched roof flashing
Ø80 - 130	IA8121	GA8334	IA8324 (5° - 25°) IA8124 (25° - 45°)

3. Determine where the flue terminal will be positioned.

5.4.1.2. Installation

1. Create a hole from the outside of the roof.

CAUTION! Make sure no debris or dust gets into the air heater.

2. Install the weather collar.
3. Carefully insert the flue terminal from the outside.

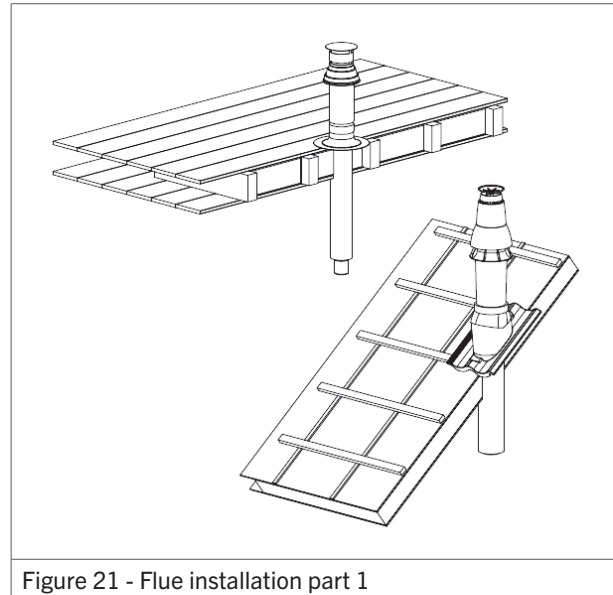

Figure 21 - Flue installation part 1

CAUTION! Do not rotate the cap.

4. Put the flue terminal into a vertical position. Use a level.
5. OPTIONAL - If desired, fit cover plates. These are supplied separately.
6. Place the supplied wall clamp around the flue terminal and fit it to the roof construction. Do not tighten the clamp yet.
7. Connect the gasket and the twin-tube connection. Make sure that the gasket is not damaged.

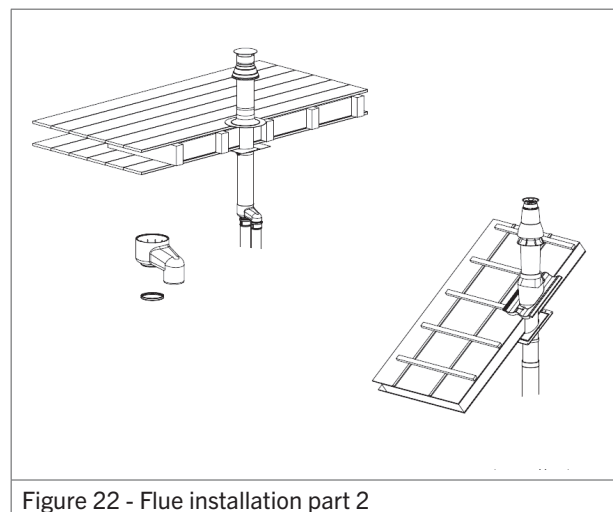

Figure 22 - Flue installation part 2

NOTICE Make sure the flue tube and the air inlet tube are not mixed up. The flue tube should be in the centre of the flue terminal.

8. Tighten the roof wall clamp.
9. Check if all steps have been carried out correctly.

5.4.2. Installation - Wall terminal

To install the flue terminal in a wall, do the following:

5.4.2.1. Preparation

1. Check all components for possible damage.
2. Determine where the flue terminal will be positioned.

5.4.2.2. Installation

1. Create a hole through the wall.

CAUTION! Make sure no debris or dust gets into the air heater.

2. Carefully insert the flue terminal from the outside.

CAUTION! Do not rotate the cap.

3. Put the flue terminal in a horizontal position. Use a level.
4. Mark the holes on the wall.
5. Drill the holes.
6. Insert screws to fix the terminal in place.
7. Seal the edges of the flue terminal with kit.
8. Fix the shield on the inside of the wall.

CAUTION! Make sure that the gasket is not damaged.

9. Connect the gasket and the twin-tube connection.

NOTICE Make sure the flue tube and the air inlet tube are not mixed up. The flue tube should be in the centre of the flue terminal.

10. Check if all steps have been carried out correctly.

5.4.3. Installation of the flue system parts

This chapter gives the instructions for installing an ALU FIX flue system.

5.4.3.1. Requirements

The installation must follow these requirements:

- Minimum distance between the flue system and combustible materials of 40 mm.
- Minimum depth of female sockets of 40 mm.
- Minimum slope of horizontal piping of 50 mm/m (3°). This allows condensate to flow to the heater.

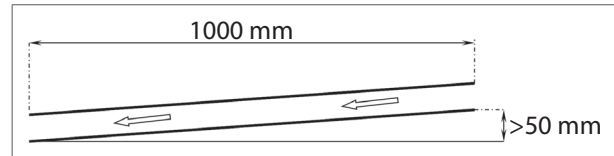

Figure 23 - Minimum slope of horizontal piping of 50 mm/m (3°)

NOTICE Use brackets that match the flue system. Different manufacturers use different connection systems for flue pipes. It is not allowed to combine systems from different manufacturers.

5.4.3.2. Elements system ALU FIX thick wall

An ALU FIX flue system is created with four elements (figure 24).

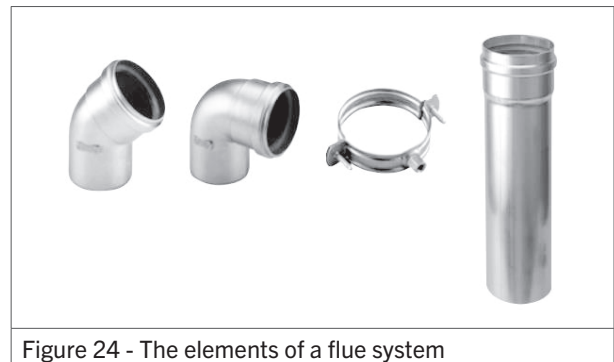

Figure 24 - The elements of a flue system

5.4.3.3. Seals

The connection between the different flue elements must be made airtight and waterproof with silicon seals.

CAUTION! If the flue elements have been cut, make sure to clean and chamfer the edges. Sharp edges will damage the seals.

CAUTION! Do not drill or screw in the flue elements.

CAUTION! Do not try to seal the connections with kit, foam or tape.

CAUTION! Do not use grease, vaseline or oil to lubricate the installation.

CAUTION! Only use the lubricant allowed by the manufacturer to lubricate the connections. A maximum soap concentration of 1% is allowed.

NOTICE Follow the instructions from the manufacturer if the connections need to be fixed.

5.4.3.4. Installation

Take note of the following rules and requirements when installing a flue system:

CAUTION! Do not apply mechanical force on the parts during installation.

Requirements for horizontal and non-vertical piping:

- Maximum distance between brackets of 1 m.
- On tensile joints; maximum distance between brackets of 2 m.

Follow the manufacturer's instructions.

- Spread the brackets evenly along the piping.

Requirements for vertical piping:

- Maximum distance between brackets of 2 m.
- Spread the brackets evenly along the piping.

Always place a bracket on or near a bend or elbow piece, except if the flue pipes before and after the elbow piece are shorter than 0.25 m. In this case, fix the second element after the elbow with a bracket.

Every flue discharge system needs to be secured with at least one bracket. The first bracket needs to be within the first 0.5 m of the air heater.

When installing a flue system inside a shaft, do the following:

1. Check the components for possible damage or blockage.
2. Check that the pipe is at the right slope (see Requirements).
3. Mark the flue pipes and fresh air pipes to avoid mixing them up.
4. Make sure that the pipes extend for at least 50 mm when passing through a wall or other obstacle.

5. Fix the last element before entering the shaft in place. If the last element is an elbow piece, the next element must also be fixed in place.
6. Check if ventilation openings and inspection hatches comply with national and local regulations.

6. Operating the air heater

6.1. Burner cycle

The air heater's display shows the current status of the burner cycle (figure 25).

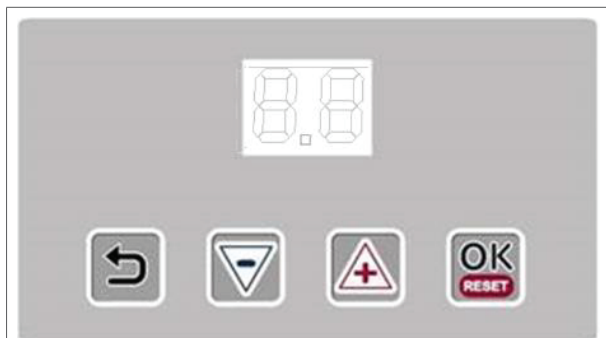

Figure 25 - Display of the air heater

Display	Status	Description	Time (seconds)
0	Stand-by	Waiting for heat demand.	-
1	Reset	Software reset.	-
3	Pre-check	Zero position check pressure switch.	-
4	Pre-purge	30 seconds of pre ventilation by the combustion fan. The pressure switch is checked.	30
5	Pre-ignition	Ignition without opening the gas valve.	-
6	Ignition	5 seconds of ignition. The gas valve opens.	-
7	Flame check	The air heater checks if the flame is present.	-
8	Burn	The heater fires up and starts to modulate.	240
9	Minimum	Before the flame stops, the burner will modulate to minimum power.	-
10	Burner off	The gas valve closes. The flame stops.	-
11	Post purge	Burner fan purges with fresh air. System fan cools the heat exchanger.	30
P	Anti-shuttle	The heater can not generate a heat demand during this period.	18
F	Ventilation	Request to start (summer) ventilation mode.	-

6.2. Minimum operating time

The gas booster of the hybrid heater will always run for a minimum of 4 minutes, even if the heat demand stops. This is to avoid large amount of starts and stops.

After this, the fan will run for 2 - 3 minutes to cool down, depending on the temperature.

When the cooling time has passed, a new heat request will be granted.

6.3. Delta-T-regulation

The air heater can function as a de-stratification fan. This is called delta-T regulation and it is done via the room thermostat, with a temperate measurement sensor that is located on the air heater.

The system fan is activated when the temperature-difference between the sensor on the heater (the delta-T NTC sensor) and the sensor in the thermostat is bigger than 12 °C (standard factory setting). This procedure ensures an even distribution of temperature throughout the building, thus acting as a fully automatic de-stratification fan.

6.3.1. Switch off delta-T-regulation

Delta-T regulation can be switched off when it is not desired (e.g. when it causes discomfort). This can be done in the **Settings** menu on the room thermostat. See the user manual of the special Room thermostat for more information.

NOTICE Delta-T regulation is automatically switched off when the delta-T sensor (sensor terminal J6) is disconnected.

6.4. Summer ventilation

The fan can be set to run in the summer. Follow the instructions in the user manual of the special Room thermostat.

6.5. Overheating protection

The air heater's heat exchanger and flue system are both protected from excessive temperatures.

6.5.1. Heat exchanger

An NTC sensor is located near (or on) the heat exchanger. This sensor monitors the heat exchanger temperature.

If the heat exchanger becomes too hot, this sensor will cause the heating process to stop. Depending on the temperature, the air heater performs the following actions:

- Step 1: Power reduction (if possible) (thermostat display: A07).
- Step 2: The burner stops, followed by an automatic restart once the unit has cooled down (thermostat display: E05 / E36).
- Step 3: The burner stops, followed by a lockout. A manual reset is required (thermostat display: L15).

6.5.2. Flue system

A flue sensor (NTC) is located in the flue system of the air heater. This sensor monitors the flue temperature.

If the flue system becomes too hot, this sensor will cause the heating process to stop. Depending on the temperature, the heater performs the following actions:

- Step 1: Power reduction (when possible).
- Step 2: Burner stop, followed by an automatic restart when cooled down.
- Step 3: The burner stops, followed by a Lock Out. A manual reset is required (thermostat display: L16).

6.6. Flue passage check

The air heater is equipped with a pressure switch that checks the passage of combustion air through the heat exchanger. The pressure switch checks if there is sufficient movement of combustion air through the heat exchanger (only during the pre-purge phase). If the pressure difference is too low, the air heater will not start. Error L-14 will be shown on the display.

7. Commissioning the air heater

7.1. Adjusting the settings

Prior to packaging, the safety and functioning of each air heater is checked in detail. It is also set to the right combustion efficiency.

In general, the heater does not need to be adjusted after installation. It is only necessary to perform a functional check and to obtain a flue gas analysis and record it for later reference.

CAUTION! Use only calibrated instruments to adjust the air heater.

CAUTION! Never carelessly turn the adjuster screws.

NOTICE Adjusting the control without a supporting flue gas analysis voids the warranty.

Only adjust the CO₂ value if the CO₂ reading differs more than 0,3% from its setting.

7.2. Commissioning the air heater

Once the unit is installed according to this manual, the unit can be commissioned. To do so, follow these instructions:

1. Make sure the gas supply pipe is clean, gas tight and free from air.
2. Switch on the electric supply with the maintenance switch.

You are now able to observe the first start-up and become familiar with the functioning of the heater.

NOTICE If the gas line is not purged correctly, the heater will attempt to start twice before going into a lock-out condition. In this case, manual reset is necessary.

1. Instruct the end user of the about a safe use of the air heater:
 - The presence of gas
 - The location of the manual gas valve

2. Instruct the end user about the operation of the heater:
 - Lock-out indication
 - Reset
3. Instruct end user about the necessary maintenance.
4. Leave this manual with the end user.

7.2.1. First use – modbus

To commission the air heater via the Smart Controller or the Building Management System, do the following:

- Create a heat-request. The hybrid air heater will activate the heat pump first. After the heat pump has started, the water will start to circulate and the fan of the hybrid heater will start.
- When the heat request remains active, and the difference between the set temperature and the actual temperature is large enough, the electrical booster will start after a while too. The booster remains activated for the minimal firing time (see §6.2 for more information).

7.2.2. First use gas booster - display

To commission the gas booster via the display's manual test mode, do the following:

NOTICE The display's manual test mode will only work for maximum 10 minutes.

1. Press and hold the **Return** and (–) button for a few seconds (figure 26). The display will alternate between Lo and St. This means the heater will start up in Low fire.
2. Press the (+) and (–) buttons to toggle between Low and High fire (figure 26).
3. Press the (–) button until 0 is displayed to exit the service. The air heater will always cool down the heat exchanger for several minutes.

The test mode will automatically end after 10 minutes.

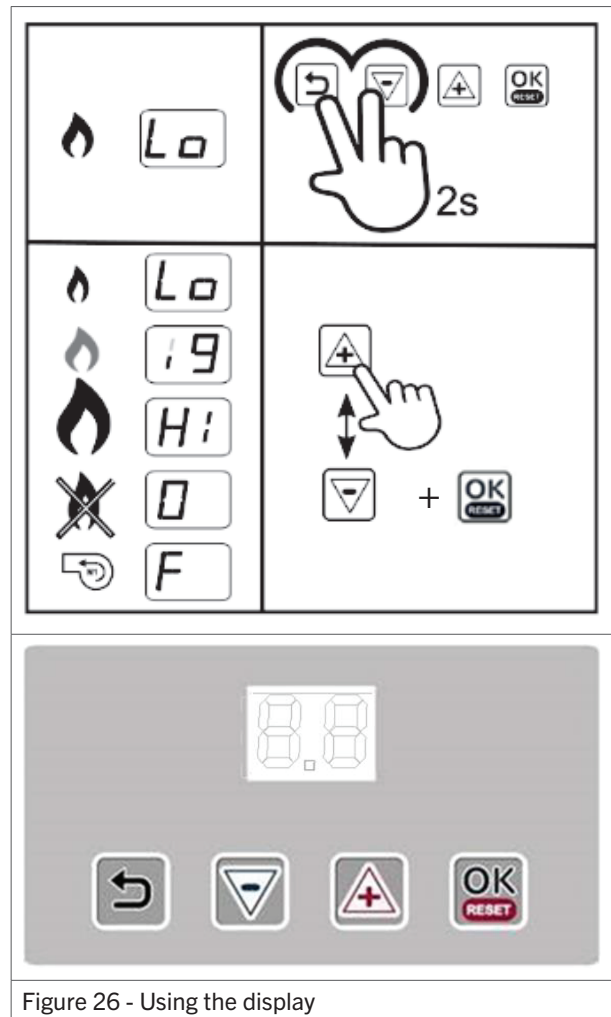

Figure 26 - Using the display

8. Combustion settings

In principle, it is not necessary to adjust the control shortly after commissioning the air heater. When the control does have to be adjusted after a period of use or after installing a new heater, this must be done by a qualified person using calibrated equipment.

DANGER! A poor adjustment can lead to overheating of the air heater and/or production of toxic carbon monoxide.

8.1. Adjusting the burner settings

The flow of gas to the burner is controlled with a gas valve. This valve must be set to the high and a low power settings of the heater. When adjusting, the CO₂ or O₂ in flue gas has to be monitored with a calibrated analyser.

The gas valve is adjusted with two screws (figure 27):

- The Offset adjuster screw for Low fire.
- The Ratio adjuster screw for High fire.

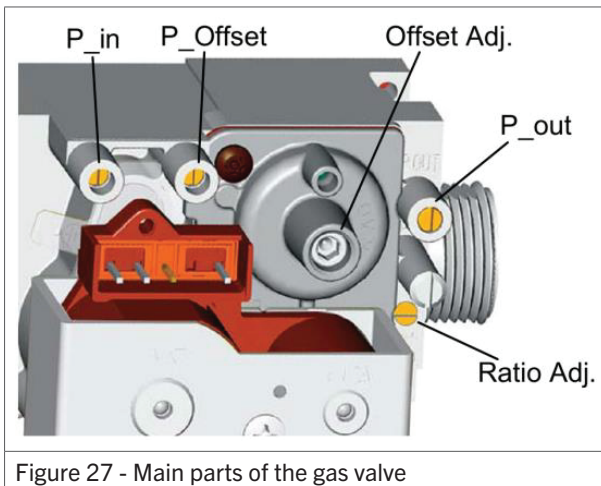

The air heater must first be commissioned at High fire.

NOTICE If the air heater does not ignite while sparking, close the air-openings of the gas-air mixer during ignition. Use your forefinger. The gas mixture will become richer and will ignite more easily.

Look for the correct CO₂ value for the air heater in §3.2. Adjust the CO₂ value if the difference is more than 0.3%:

1. Check the CO₂ value in High fire (Hi).
2. Turn the Ratio adjuster screw to the right to decrease the CO₂ value.

3. Turn the Ratio adjuster screw to the left to increase the CO₂ value.
4. Check the CO₂ value in Low fire (Lo). The CO₂ value in Low fire should be lower than in High fire.
5. Turn the Offset adjuster screw to the left to decrease the CO₂ value.
6. Turn the Offset adjuster screw to the right to increase the CO₂ value.
7. Return to High fire (Hi) and readjust the CO₂ value with the Ratio adjust screw.
8. Return to Low fire (Lo) and readjust the CO₂ value with the Offset adjuster screw.
9. Repeat the steps above until both CO₂ values are ok.

DANGER! Always measure the air heater's CO production. Too much CO usually means the gas mixture is too rich. Adjust this if necessary with the two adjusters (figure 27). The concentration of CO should always be below 100 ppm.

8.2. Converting to another gas type

CAUTION! The air heater's gas type may only be converted by the manufacturer or its representative. Contact your supplier for more information.

9. Troubleshooting

If the air heater malfunctions, first check if the problem is caused by external circumstances (e.g. no supply power). If the problem is not caused by external circumstances, use the tables and instructions in this chapter to fix the air heater.

NOTICE Please remember the built in waiting times of the air heater; the signals of the LED's and the code on the display. Do not react too soon.

The error codes below, refer to the gas booster of the hybrid air heater. The error codes of the connected heat pump are visible in the Smart Controller too. Consult the manual of the heat pump for details.

9.1. Volatile lock outs

The table below describes the volatile lock outs that can occur. These can only be reset by hand.

Display	Error type	Description	Case #
L-0	Internal error	Internal error	13
L-1	Internal error	Flame lasts only 5 seconds after ignition	1
		No flame after ignition	2
L-2 and 3	Internal error	Internal error	13
L-4	E-error	E-error for more than 24 hours	12
L-5	Burner fan error	Burner fan does not work	6
L-6 and 7	Burner fan error	Burner fan rotates at the wrong speed	7
L-8 to 12	Internal error	Internal error	13
L-13	Pressure switch error	Pressure switch is closed in stand-by mode	14
L-14	Pressure switch error	Pressure switch does not close during pre-purge	11
L-15	Overheating	Heat exchange sensor is overheated	3
L-16	Flue temperature error	Flue sensor is overheated	3
L-17 to 19	Internal error	Internal error	13
L-20	Flame error	Flame detected after closing the gas valve	15
L-21	Flame error	Flame detected before opening the gas valve.	16
L-22	Flame error	Flame failure during burning	5
L-25	Sensor error	Heat exchange sensor failure	4
L-26	Sensor error	Flue sensor failure	4
L-27 to 31	Internal error	Internal error	13

Display	Error type	Description	Case #
L-32	Sensor error	Heat exchange sensor failure	4
L-33 to 38	Internal error	Internal error	13
L-42	Flue temperature error	Too many flue temperature errors	3
L-43	Overheating	Heat exchange sensor is overheated too often	3

9.2. Temporary errors

The table below describes the temporary errors that can occur. These will disappear automatically after the cause has been resolved.

Display	Error type	Description	Case #
E-00 to 04	Internal error	Internal error	13
E-05	Overheating	Heat exchange sensor is overheated	3
E-06 to 13	Internal error	Internal error	13
E-14	Flame error	Flame detected when there shouldn't be one	16
E-15 to 19	Internal error	Internal error	13
E-21 and 22	Heat exchanger sensor error	Heat exchanger sensor not detected	4
E-22	Internal error	Internal error	13
E-23 and 24	Flue sensor error	Flue sensor not detected	4
E-27 and 28	Heat exchanger sensor error	Heat exchanger sensor short-circuit	4
E-30 and 31	Flue sensor error	Flue sensor short-circuit	4
E-34	Reset button error	Too many reset actions in a short timespan	9
E-36	Overheating	Heat exchange sensor is overheated	3
E-38 and 39	Heat exchanger sensor error	Heat exchanger sensor not detected	4
E-47 and 48	Heat exchanger sensor error	Heat exchange sensor short-circuit	4
E-49 to 64	Internal error	Internal error	13
E-65	Voltage too low	Supply voltage is too low for over 1 minute	-
E-66	Voltage too high	Supply voltage is too high for over 1 minute	-
E-67	Pressure switch error	Too many pressure switch errors	11
E-68	Flue temperature error	Flue sensor is overheated	3
E-69	Configuration error	Heater configuration error	19
E-70	ADC error	Sensor value is measured incorrectly	13

9.3. Warnings

The table below describes the temporary warnings that can occur. The heater may still be working, or stops until the cause has been resolved.

Display	Error type	Description	Case #
A-00	Communication error	Communication error for more than 4 minutes	20
A-02	Configuration error	Heater configuration error	19
A-07	Overheating	Heat exchange sensor is almost overheated	3
A-08	Overheating	Flue sensor is almost overheated	3

9.4. Instructions

After identifying the problem, use the Case number to find the possible cause in this paragraph.

Case 1: Flame lasts only 5 seconds after ignition.

- The flame is not detected:
 - Check the ignition/ionisation cable and the electrode. The cable should have a resistance of 1 k Ω .
- The air heater is not earthed properly.
- The circuit board is defective.

Case 2: No flame after ignition.

- There is not enough gas pressure.
- The gas mixture is too poor:
 - Adjust the gas valve (see §8.1).
- The gas valve does not open:
 - During ignition, check for a 230 V voltage on the valve.
- Check if the ignition electrode sparks. If not:
 - Check the cable and electrode and replace them when damaged.
 - Check the burner control unit and replace it when it does not give a spark output.

Case 3: Heat exchange sensor or flue sensor is overheated.

- Check if the connectors J12 and J6 are plugged in correctly and if the connection J12[1-4] (optional overheating protection) is closed.
- Check if the system fan supplies enough air.
- Check the settings of the gas valve. The heater may be overfired. If so:
 - Adjust the burner pressure.

Case 4: Heat exchange sensor or flue sensor not detected, or short circuit.

NOTICE L-25 refers to the heat exchange sensor. L-26 refers to the flue sensor, if applicable.

- The heat exchange sensor consists of two internal sensors. The readings of these sensors may differ too much:
 - Measure the resistance of each sensor. The resistance should be 20 k Ω at 25 °C and 25 k Ω at 20 °C.
 - If the measured values differ too much, replace the sensor.

Case 5: Too many flame failures while burning.

- The gas supply is not constant. This results in a drop in gas supply pressure while burning and causes the flame to extinguish.
 - Check the gas supply pressure while the heater is burning.
- The burner pressure for Low fire is too low. This causes the flame to extinguish because it is too small to be detected.
 - Check the burner pressure at Low fire and adjust if necessary (see §8.1).
- Recirculation of flue gas. Due to a problem with the flue terminal the flue gas is sucked back into the air inlet. This results into a lack of oxygen and causes the flame to stop.
 - Check the flue system and fresh air supply. Only certified, original parts should be used.

Case 6: Burner fan does not work.

- Check if the burner fan is blocked.
- Check if the wiring is damaged.
- The burner fan is defective.

Case 7: Burner fan rotates at the wrong speed.

- Check if the burner fan runs smoothly.
- Check if the wiring is damaged.

Case 9: Too many reset actions in a short timespan.

- This error will disappear after some time or if the main power is disconnected for a while.

Case 11: Insufficient air passage through the heat exchanger. Pressure switch does not close.

- Check if the combustion fan is running.
- Check if the flue system is blocked or restricted.
- Check the pressure switch and the connections.
- Check the heat exchanger for flue leakage.

Case 12: E-error for more than 24 hours.

- Switch the air heater off and on and check the error code.

Case 13: Internal error.

- Isolate the electrical supply and reenergise. If this does not help:
 - Replace the burner control unit.

Case 14: Pressure switch is closed in stand-by mode.

- Check if the contact is stuck. If so:
 - Replace the pressure switch.
- Check if there is water in the hose. If so:
 - Dry the hose.

Case 15: Flame detected after closing the gas valve.

- Check if the gas valve closes too slow. If so:
 - Replace the gas valve.
- Check if the ionisation electrode is wet. If so:
 - Dry, clean or replace the electrode.

Case 16: Flame detected before opening the gas valve.

- Check if there really is a flame before ignition. If so:
 - Replace the gas valve.
- Check if the ionisation electrode is wet. If so:
 - Dry, clean or replace the electrode.

Case 19: Heater configuration error

- The heater does not know which program to run, due to a mismatch between the burner control unit and the display. If so:
 - Contact your supplier.

Case 20: Communication time-out.

- Communication has been interrupted for more than 4 minutes.
 - Check if the Smart Controller of Building Management System (BMS) is still operating.

9.5. Further troubleshooting

When the air heater does start but shows a different problem than described above, check if the following problems apply.

9.5.1. Explosive ignition and/or frequent flame failures

- Check if the gas control settings are correct (see §8.1). A correct CO₂ value is important for a proper ignition.

- Check the ignition cable. It should have a resistance of 1 kΩ.
- Check the position of the ignition electrode. The spark has to be formed between the two electrodes, not between the electrode and the burner.

9.5.2. Insufficient output

The heat output of the air heater is insufficient if there is too much resistance in the inlet or outlet flue system. The burner fan still rotates at full speed, but the resistance prevents enough gas mixture from entering the burner.

- Check the flue system for blockage.
- Check the burner for dust or other pollution.

9.5.3. Non modulating system fan

System fan (M1) sometimes does not start or does not vary in speed.

- Check the functioning of this fan by connecting it to a supply of 230 V.
- Check if the fan is energised. Use a multi-meter. If so, the cause of the problem lies in the burner control unit.

10. Maintenance

CAUTION! The air heater must be inspected and cleaned once a year by a qualified installer with sufficient knowledge about the device.

CAUTION! Sufficient maintenance is critical in circumstances such as high humidity, dust, high switching on/off frequency, etc.

10.1. Preparation

Before performing maintenance on an air heater that is already installed, do the following:

1. Set the thermostat to the lowest setting.
2. Close the manual gas valve.
3. Turn off the power supply to the air heater using the maintenance switch.

CAUTION! Always check for gas leaks after working on the air heater.

CAUTION! Do not use water when cleaning the air heater.

CAUTION! The heater must be electrically isolated during servicing.

10.2. Basic maintenance

To perform basic maintenance on the air heater, do the following:

CAUTION! When cleaning parts of the air heater, use a dry cloth, brush, compressed air or a vacuum cleaner. Never use a steel brush.

1. Inspect the outside of the heat exchanger.
2. Clean the fan guard on the outside of the heater. Clean the fan blades if required.
3. Open the access panel.
4. Clean the inside of the air heater. Focus on the following parts:
 - Body
 - Fan blades and motor
 - Heat exchanger
 - Temperature sensor
 - Vane switch (if present)
5. Clean the siphon at least once a year and refill it with clean water afterwards.
6. Check if the wiring, nuts and bolts are properly secured and tightened.
7. Grease any parts and bolts that are regularly loosened for maintenance.
8. Open the manual gas valve in the supply line and

check if the supply lines are air tight, do not leak and do not contain air.

Some checks can only be performed when the heater is running. Do the following:

1. Reconnect the air heater to the power supply.
2. Switch on the air heater.
3. Check if the heater operates without problems. See §9 if any errors occur.
4. Check the air heater's combustion efficiency. If necessary:
 - Adjust the burner settings (see §8.1).

10.3. Maintenance of the burner unit

The burner unit is an important part of the air heater and requires special maintenance.

To perform maintenance on the burner unit, do the following:

1. Remove the gas pipe between the gas valve and the combustion fan.
2. Remove the ignition and fan wires.
3. Unscrew the socket screws (M6).
4. Remove the burner unit from the air heater, complete with flange and pre-mix fan.
5. Disassemble the burner unit.
6. Adjust the ignition electrode:
 - a. The distance between the electrode and the burner should be $5.0 (\pm 0.5)$ mm (figure 28).
 - b. The distance between the two electrodes should be $3.6 (\pm 0.4)$ mm (figure 29).
 - c. Check the setting of the ignition electrode. The spark should be formed between the two electrodes, not between the electrode and the burner.

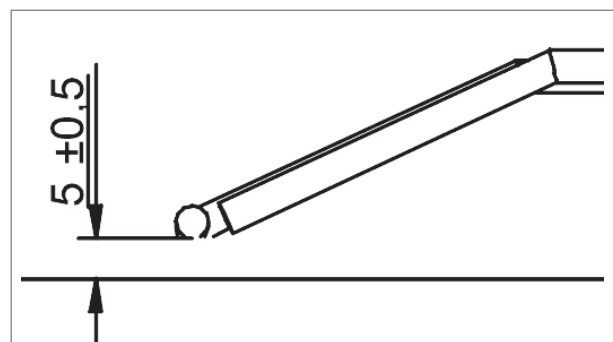

Figure 28 - Distance between the electrode and the burner

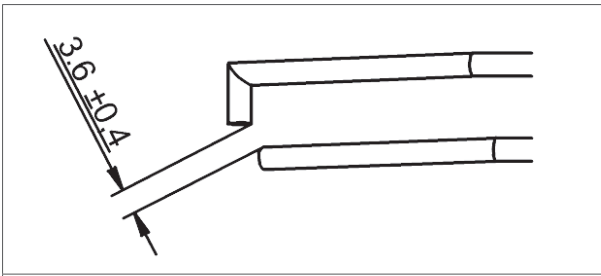

Figure 29 - Distance between the two electrodes

7. Reassemble the burner unit and install it back in the air heater.
 - Use new gaskets.

10.4. Maintenance in dusty environments

The grid in front of the burner may become clogged in dusty environments.

1. Remove the burner fan.
2. Clean the grid with a brush and a vacuum cleaner.
3. Place the burner fan back.



Figure 30 - The grid in front of the burner

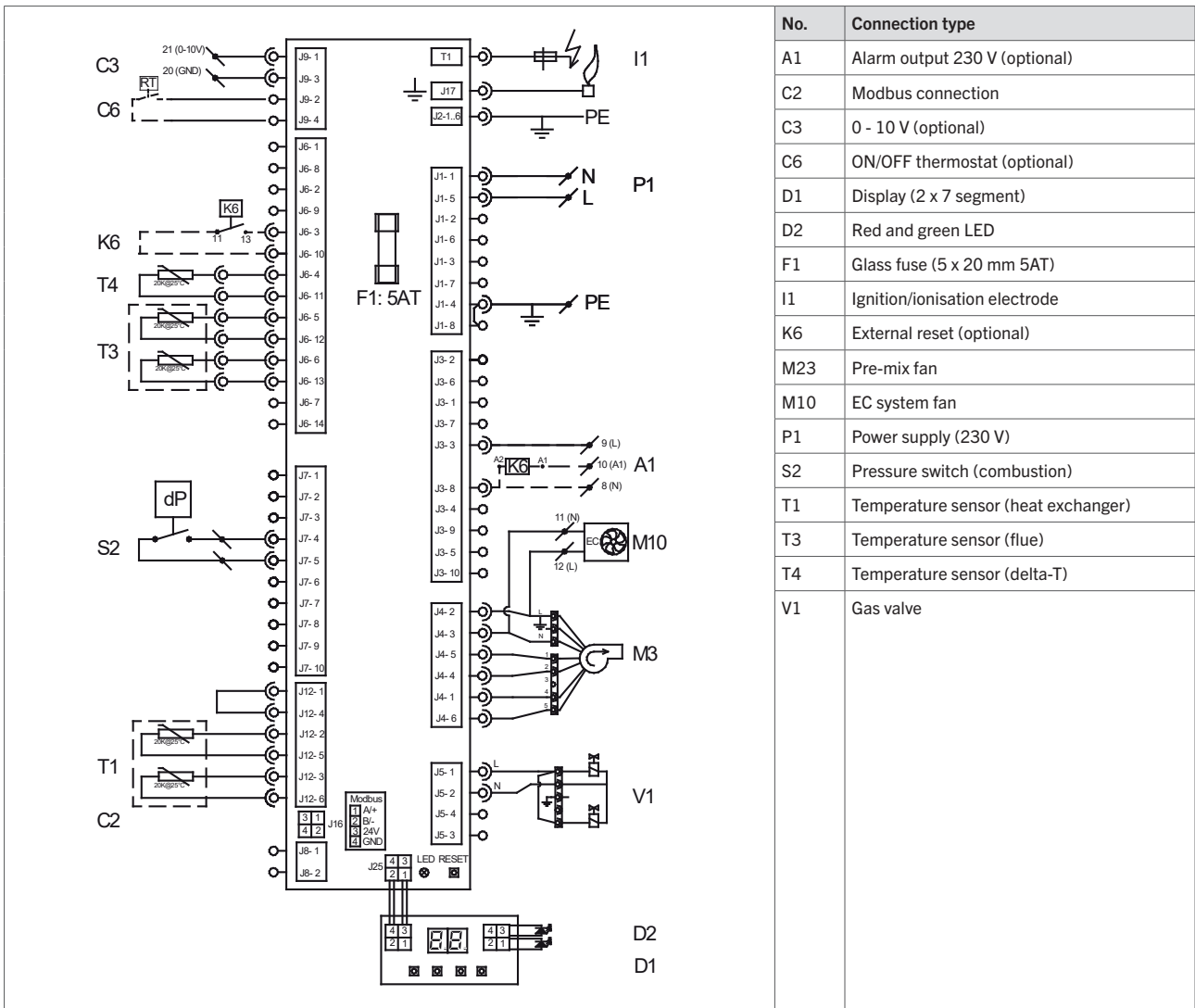

Figure 32 - Electrical wiring diagram QSG

12. Exploded view, spare parts and accessories

12.1. Exploded view and spare parts

The parts of the air heater are shown in an exploded view in figure 33. The table below describes each part and shows the correct article number for a replacement part.

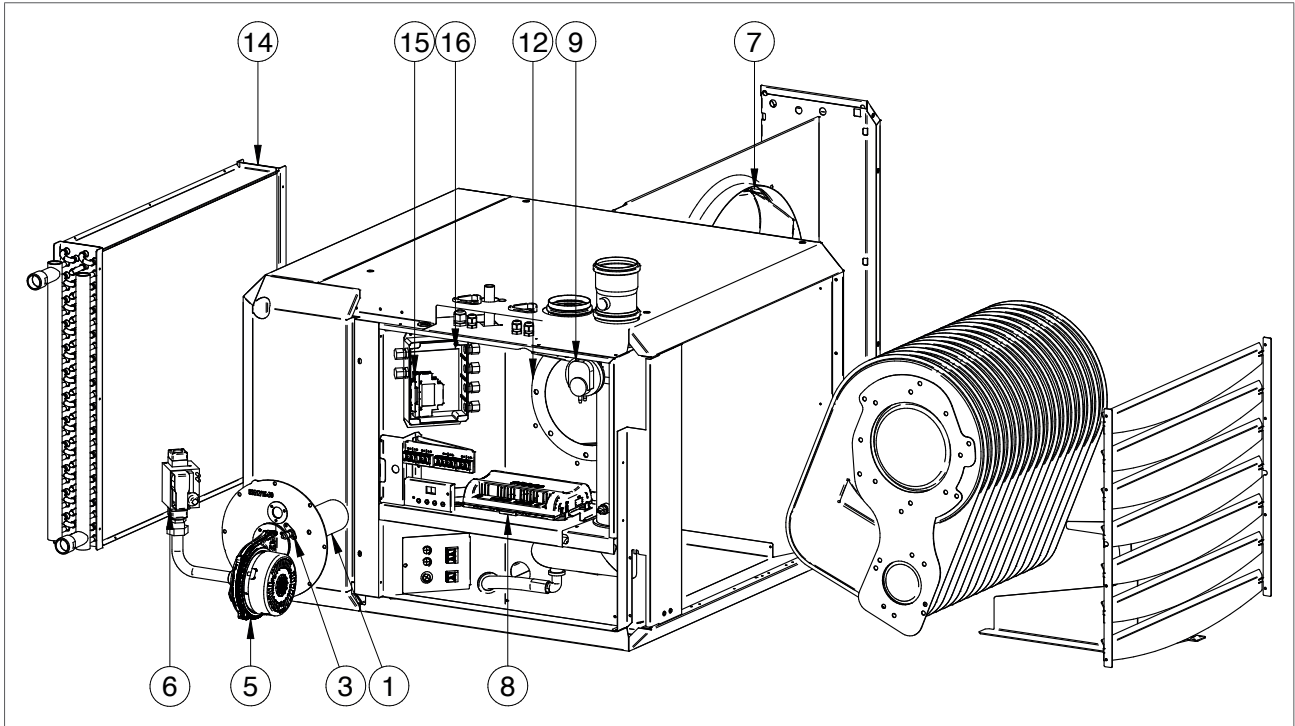



Figure 33 - Exploded view of the QSG

No.	Description	QSG6 + 10	QSG6 + 20	QSG12 + 20	QSG12 + 30	QSG12 + 40	QSG16 + 20	QSG16 + 30	QSG16 + 40	QSG16 + 50	QSG30 + 60
1	Burner set natural gas	GA3260	GA3262	GA3270	GA3270	GA3272	GA3270	GA3270	GA3272	GA3268	GA3268
3	Ignition / ionisation set	GA3460	GA3460	GA3460	GA3460	GA3460	GA3460	GA3460	GA3460	GA3460	GA3460
5	Combustion fan	GY4523	GY4523	GY4523	GY4523	GY4523	GY4523	GY4523	GY4523	GY4523	GY4523
6	Gas valve	GA3000	GA3000	GA3000	GA3000	GA3000	GA3000	GA3000	GA3000	GA3000	GA3000
7	System fan	GX4223	GX4223	GX4225	GX4225	GX4225	GX4225 (2x)	GX4225 (2x)	GX4225 (2x)	GX4225 (2x)	IX4224 (4x)
8	Burner control unit	GY5901	GY5901	GY5901	GY5901	GY5901	GY5901	GY5901	GY5901	GY5901	GY5901
9	Pressure switch	GX3932	GX3932	GX3932	GX3932	GX3932	GX3932	GX3932	GX3932	GX3932	GX3932
12	Gasket set	GA6702	GA6702	GA6702	GA6702	GA6702	GA6702	GA6702	GA6702	GA6702	GA6702
14	Heat exchanger	IH4024	IH4024	IH4026	IH4026	IH4026	IH4028	IH4028	IH4028	IH4028	IH4030
15	Power supply (24 V)	IW8022	IW8022	IW8022	IW8022	IW8022	IW8022	IW8022	IW8022	IW8022	IW8022
16	Modbus controller	IW8010	IW8010	IW8010	IW8010	IW8010	IW8010	IW8010	IW8010	IW8010	IW8010
	Sensor heat exchanger	GY3932	GY3932	GY3932	GY3932	GY3932	GY3932	GY3932	GY3932	GY3932	GY3932
	Delta-T sensor	GY3931	GY3931	GY3931	GY3931	GY3931	GY3931	GY3931	GY3931	GY3931	GY3931

12.2. Table with accessories QSG

Accessory	QSG6	QSG12	QSG16	QSG30
Heat pump HPX06A	GHW8000	-	-	-
Heat pump HPX12A	-	GHW8006	-	-
Heat pump HPX16A	-	-	GHW8008	-
Heat pump HPX30A	-	-	-	GHW8009
Smart Controller (Included)	IW8050	IW8050	IW8050	GHW8009
Power Switch 4 p, 400 V, 25 A	IK5281 (depending on model, check max. power)			
Power Switch 4 p, 400 V, 32 A	IE5209 (depending on model, check max. power)			
Power Switch 4 p, 400 V, 63 A	IE5210 (depending on model, check max. power)			
Roof duct for heat pump 100 mm	IW8032 (depending on the piping used)			
Roof duct for heat pump 140 mm	IW8031 (depending on the piping used)			
Wall support QSG	GA8610	GA8580	GA8580	GA8580
Wall support HPX06-16A	GA8650	GA8650	GA8650	-
Wall support HPX30A	-	-	-	GA8650
Vertical louvre set QSG6 (4 pcs.)	GX2003	-	-	-
Vertical louvre set QSG12 (4 pcs.)	-	GX4002	-	-
Vertical louvre set QSG16 (5 pcs.)	-	-	GX6002	-
Roof flashing Ø 80 - 130 mm	IA8121	IA8121	IA8121	IA8121
Synthetic tile	GA8334	GA8334	GA8334	GA8334
Vertical flue terminal CT 80 / 125	IA8214	IA8214	IA8214	IA8214
Horizontal flue terminal DDV 80 / 125 HR	IA8216	IA8216	IA8216	IA8216
Universal pitched roof flashing (5 ° - 25 °)	IA8324	IA8324	IA8324	IA8324
Universal pitched roof flashing (25 ° - 45 °)	IA8124	IA8124	IA8124	IA8124
Anti-frost valve 1 " x 1 "	IW8040	IW8040	IW8040	-
Anti-frost valve 1¼ " x 1¼ "	IW8038	IW8038	IW8038	-
Anti-frost valve 1½ " x 1½ "	IW8039	IW8039	IW8039	IW8039
Automatic venting 1 "	IW8472	IW8472	IW8472	-
Automatic venting 1¼ "	IW8473	IW8473	IW8473	-
Automatic venting 1½ "	IW8474	IW8474	IW8474	IW8474
Pressure meter	IW8471	IW8471	IW8471	IW8471
Filter, included	IW8451	IW8451	IW8451	IW8476
Filling accessory	IW8470	IW8470	IW8470	-
Buffer tank	IW8475	IW8475	IW8475	IW8475
Ball valve 1 "	IW8467	IW8467	IW8467	-
Ball valve 1¼ "	IW8468	IW8468	IW8468	-
Ball valve 1½ "	IW8469	IW8469	IW8469	IW8469
Rubber setup block + attachments, 2 pcs. L 600 – H 95 mm	IW8043	IW8043	IW8043	-
Rubber block for extra height, 1 pc. L 600 – H 120 mm	IW8044	IW8044	IW8044	-
Rubber setup block + attachments, 1 pcs. L 1000 – H 95 mm	-	-	-	IW8036
Rubber block for extra height, 1 pc. L 1000 – H 120 mm	-	-	-	IW8037

13. Disposal and recycling

	<p>The meaning of the symbol on the material, its accessory or packaging indicates that this product shall not be treated as household waste. Please, dispose of this equipment at your applicable collection point for the recycling of electrical and electronic equipments waste. In the European Union and Other European countries which there are separate collection systems for used electrical and electronic product. By ensuring the correct disposal of this product, you will help prevent potential hazards to the environment and to human health, which could otherwise be caused by unsuitable waste handling of this product. The recycling of materials will help conserve natural resources. Please do not therefore dispose of your old electrical and electronic equipment with your household waste.</p>
---	---

14. Declaration of conformity

Winterwarm Heating Solutions B.V.
Olden Goorweg 1
7108 AE, Winterswijk
The Netherlands

Declares that air heater types:

- QSG6 + 10, QSG6 + 20, QSG12 + 20, QSG12 + 30, QSG12 + 40, QSG16 + 20, QSG16 + 30, QSG16 + 40, QSG16 + 50, QSG30 + 60
 - CE PIN: 0063B03156

are in accordance with the essential requirements of the relevant EU directives, being:

- 2016/426/EU (GAR) relating to appliances burning gaseous fuels
- 2014/35/EU (LVD) relating to the electric safety of appliances
- 2014/30/EU (EMC) relating to electromagnetic compatibility of appliances
- 2023/1230 / EU (Machinery regulation)
- 2016/2281/EU (ECO design) relating to ecodesign requirements for air heating products

Goods should be installed and used in accordance with our instructions and with the applicable local and international rules. Installation should be done by an authorized, qualified and competent installer.

Winterswijk, December 1st 2025

 <p>WINTERWARM HEATING SOLUTIONS B.V. Olden Goorweg 1 7108 AE Winterswijk Tel. 0543-546300</p>

Ir. M. Fiselier
Technical director

